

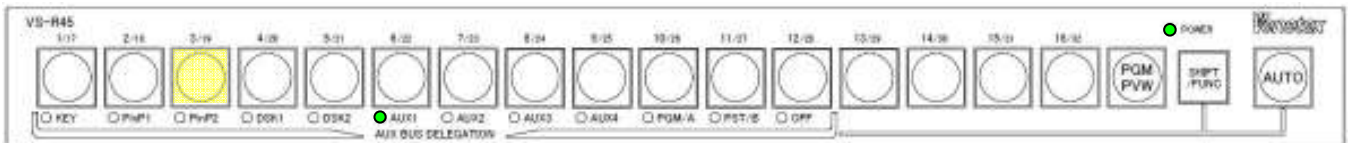

Remote Control Panel for Panasonic Multi Format Live Switcher AV-HS450/410N/400A

# VS-R45

## Operation Manual



Thank you for purchasing a Venetex product.

■ Please review the Operation Manual for proper and safe operation.

Please read “Important Safety Instructions” section before operating the product.

Please keep the Operation Manual in a secure place for future reference.

## - Table of Contents -



Important Safety Instructions (Please be sure to follow the following guidelines.)	3
Please follow the following general instructions.	7
1. Overview	8
2. Key Features	8
3. Accessories	8
4. Part Names and Functions	9
4-1. AV-HS450 Connection	9
4-2. AV-HS400A Connection	10
4-3. AV-HS410N Connection	11
5. Operation Mode Settings	12
6. Connecting	13
6-1. AV-HS450 Connection	13
6-2. AV-HS400A Connection	15
6-3. AV-HS410N Connection	16
7. Turning on the Power	18
8. Operating the Unit	19
8-1. AV-HS450 Connection	19
8-1-1. Turning on the Power	19
8-1-2. Current Bus Status and Selecting Bus	19
8-1-3. Key Lock	20
8-1-4. Selecting the Material	20
8-1-5. AUTO Button	22
8-1-6. Selecting the Bus on Initial Power-up	23
8-2. AV-HS400A Connection	24
8-2-1. Turning on the Power	24
8-2-2. Current Bus Status and Selecting Bus	24
8-2-3. Key Lock	25
8-2-4. Selecting the Material	25
8-2-5. AUTO Button	26
8-2-6. Selecting the Bus on Initial Power-up	26
8-3. AV-HS410N Connection	27
8-3-1. Turning on the Power	27
8-3-2. Current Bus Status and Selecting Bus	27
8-3-3. Key Lock	28
8-3-4. Selecting the Material	28
8-3-5. PinP Trans Button	30
8-3-6. AUTO Button	30
8-3-7. Selecting the Bus on Initial Power-up	31
9. System setup	32
9-1. IP Address setting	32
10. Specifications	36
10-1. Device Specifications	36
10-1-1. AV-HS450 Connection	36
10-1-2. AV-HS400A Connection	37
10-1-3. AV-HS410N Connation	38
10-2. RS-422 Specifications	39
11. Outline Dimensions	40
12. Customer Support	41

# Important Safety Instructions (Please be sure to follow the following guidelines.)



The following Important safety instructions are outlined to prevent harm to property, users, and others.

- Please read the following instructions.
- Please retain the following instructions in a secure place.
- Please pay attention to all warnings.
- Please follow the following instructions.









■ The following symbols and descriptions are used to categorize the degrees of harm that may occur as a result of failing to follow instructions for the proper operation.

	<b>Warning</b>	The action may cause a "possible risk of serious personal injury or death."
	<b>Caution</b>	The action may cause a "possible risk of personal injury or property damage."

■ The following symbols and descriptions are used to categorize the instructions to be followed.

	This symbol indicates "Do Not Try" actions.
	This symbol indicates "Strictly Prohibited" actions.
	This symbol indicates "Caution."

## **Cautions**

<p><b>Do not place the device on unstable surfaces!</b></p> <p> This may cause injury due to the device falling or toppling over.</p>	<p><b>Do not place heavy items on the cable!</b></p> <p> This may damage cable and cause fire/electric shock. Make sure that the device is not placed over the cable.</p>
<p><b>Do not place the device near water!</b></p> <p> This may cause fire and electric shock.</p>	<p><b>Do not plug or unplug the cord with wet hands!</b></p> <p> This may cause electric shock.</p>
<p><b>Always use specified accessories and options!</b></p> <p> Failure to do so may cause fire and accident.</p>	<p><b>Do not use power sources or voltage other than indicated!</b></p> <p> This may cause fire and electric shock.</p>
<p><b>Do not operate the device near water.</b></p> <p> This may cause fire and electric shock.</p>	<p><b>Do not place item containing liquid or small metals on top of the device!</b></p> <p> This may cause breakdown and accident.</p>

# Important Safety Instructions (Please be sure to follow the following guidelines.)



## Caution

### Do not wet or have water leak into the device!



This may cause fire/electric shock. Please use extra caution when operating in rain or snow, on the beach or near the water.

### Do not insert or jam a foreign object into any open slots!



This may cause fire/electric shock.

### Do not break, damage, modify the cord! Do not place the cord near high temperature! Do not force the cord to bend, twist or pull! Do not place a heavy item on the cord! Do not roll up or wrap the cord!



This may cause electric shock, short circuit and fire  
■ Please consult the dealer about cord and plug repairs.

### Do not modify this device!



This may cause fire and electric shock.

### Do not remove any housing covers from the device!



This may cause electric shock  
■ Please contact the dealer about maintenance and repairs.

### Do not remove the cover!



This may cause electric shock.  
■ Please contact the dealer about maintenance and repairs.

### Always unplug the power cord when the device is damaged or dropped!



It may cause fire and electric shock otherwise.

### Always unplug cables when a foreign object falls inside the device!



It may cause fire and electric shock otherwise.

### Always unplug the power cord when the device gets wet inside!



It may cause fire and electric shock otherwise.

### Always unplug cables when the device displays an abnormal sign such as smoke or burning smell!



It may cause fire and electric shock otherwise.  
■ Please contact the dealer to request a repair.

### Please ask the service technician for repairing the device.



The repair service must be performed by the trained technician.  
In case of damage of power cord or plug, leak of liquid, insertion of foreign object into the device, any damage to the device, exposed to rain or water, not working properly, and dropping the device, the repair service is required.

# Important Safety Instructions (Please be sure to follow the following guidelines.)



## Caution

**Do not place cables close to heating apparatus!**



This may cause fire and electric shock by melting cable shields.

**Do not expose the device to oily smoke or steam!**



This may cause fire and electric shock.

**Do not place the device in areas subject to moisture or excessive dust!**



This may cause fire and electric

**Do not unplug by pulling the cord!**



This may damage the cord and cause fire and electric shock.

■ Be sure to hold the plug and pull out.

**Do not block any ventilation openings of this device!**



This may cause fire by heating up inside the device.

Do not:

- Jam the device into the area with no air circulation, or
- Cover the device with table cloth or place it on carpet.

**Do not plug or unplug with wet hands!**



This may cause electric shock.

**Do not place a heavy item on the device!**



This may damage the device or it could fall and injure the user.

**Do not stand on this device!**



This may cause injury by falling and breaking.

**Do not transport the device with connected cords!**



This may damage the cords and cause fire and electric shock.

**Always unplug the cord when cleaning the device!**



This will prevent fire and electric

**Consult the dealer about cleaning the device once a year!**



This will prevent fire and short circuit caused by excessive dust.

**The product should be cleaned only with a dry cloth.**



The product should be cleaned only with a dry cloth, otherwise may cause fire/electric shock.

# Important Safety Instructions (Please be sure to follow the following guidelines.)



## Caution

### Do not pinch or crush the cable.



Do not crush or pinch the power code particularly at plugs, convenience receptacles, and the point where they exit the device, this may cause fire and breakdown .

### Use the attachment such as bracket etc., recommended or specified by Venetex Corporation.



Use only brackets and screws specified by Venetex Corporation, and also should use those with the device in the package. They may cause injury by falling, and also cause of breakdown and damage of the device.

### I take off a power supply plug!.



When it is thunder storm or during extended periods when the device is not used, unplug it from the power source to avoid breakdown by thunder striking.

## Please follow the following general instructions.

---

■ **Operate the device in the range of temperature 0°C ~ +40°C (or 32F to 104F).**

Internal parts may fail if operated out of the specified range.

■ **Turn off the power before connecting or disconnecting the cables.**

Turn off the power before connecting or disconnecting the cables.

■ **Use in an area with no excess moisture dust.**

Using the device in an environment with high moisture or excessive dust may cause internal parts to fail.

■ **Cleaning**

Turn the power off and wipe the surface with dry cloth. If more persistent cleaning is necessary, damp a towel with a small amount of diluted kitchen detergent to wipe the surface. Wipe again with a clean damp towel, then with a dry towel.

■ **Note:**

Please do not use volatile liquid such as benzene or paint thinner to clean the device.

Please follow the instructions carefully before using the chemically treated cleaning cloth with the device.

## 1. Overview

The VS-R45 is a remote control panel that can maximize the functionality of Panasonic switcher.

- It allows you to select materials for main buses.
- It has flexible structure, which allows cable connection from three directions such as for the console and the rack installation.
- It adopts the same switching mechanism with Panasonic switcher, allowing easy operation with higher compatibility.

**VS-R45 works for Panasonic AV-HS450, AV-HS400A and AV-HS410N.**

**It is possible to select Panasonic switcher by setting of MODE SW of VS-R45.**

**The pin 2 and 3 of MODE SW determine the connection of AV-HS450, AV-HS400A and AV-HS410N. AV-HS410N needs to download plug-in software from Panasonic homepage and needs to install it in switcher.**

**※Remark: Between AV-HS400A and VS-R45 is connected with RS-422 only.**

## 2. Key Features

Cross-point setting is used to select materials for the following buses:

- AUTO Transition is available for AUX1 bus.  
(Note: Effects and Time settings are configured from the main switcher unit.)
- The switches and buttons can be locked to avoid operation error.
- The rotary switch located in rear panel controls the selection of the bus when power is turned on.

## 3. Accessories

- Rack Mount Bracket; (2 pieces.)



- Screws for Bracket Attachment (M4 x 10 W, x 4)



- Panel Change Kit for AV-HS400A  
(Please use this kit for AV-HS400A connection only.)



- Panel Change Kit for AV-HS410N.  
(Please use this kit for AV-HS410N connection only.)





## 4. Part Names and Functions

### 4-1. AV-HS450 Connection

#### ■ Front View

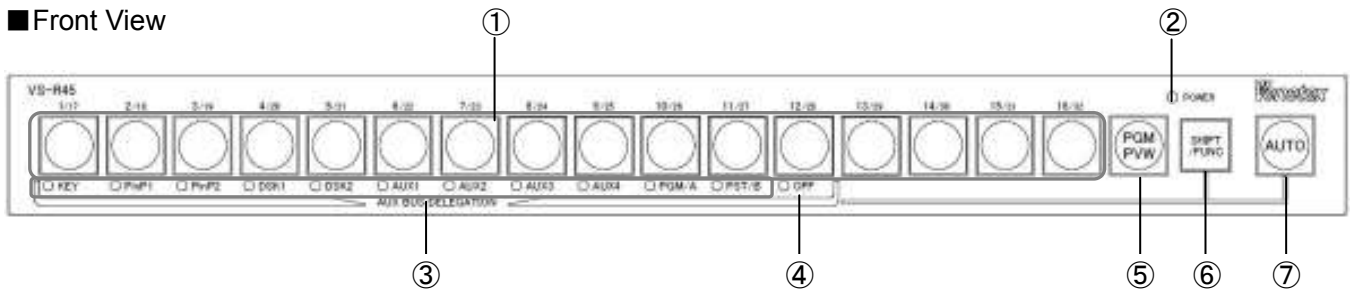

#### ① Material/Bus Selection Buttons

To select materials

To select a bus, press a button while pressing SHIF/FUNC + AUTO simultaneously. Button light will be on for the currently selected material.

#### ② Power Indicator

Green light is on when the device power is on.

#### ③ Bus Status Indicator

Indicates the current active bus.

Green light is on for the active bus.

#### ④ Key Lock Indicator

Green light is on when Key Lock is in effect.

#### ⑤ PGM/PVW Button

To select PGM or PVW Material.

Press once to choose PGM. Press once along with SHIFT/FUNC button for PVW.

#### ⑥ SHIFT/FUNC Button

To select Material #17 and up.

#### ⑦ Auto Button

To turn on AUTO Transition.

#### ■ Rear View



#### ⑧ RS-422 Connector

Connector for RS-422 Cable

#### ⑨ Ground Terminal

To Connect ground wire

#### ⑩ LAN Connector

To connect LAN cable

※Available in 2010

#### ⑪ Dip Switch for Mode Selection

Dip Switch allows you to select operation mode.

#### ⑫ Rotary Switch for Bus Selection

To assign the bus on initial power-up.

#### ⑬ DC Cable Clip

To fasten the device to avoid power cable disconnection

#### ⑭ DC Jack

Female DC plug

## 4-2. AV-HS400A Connection

### ■ Front View

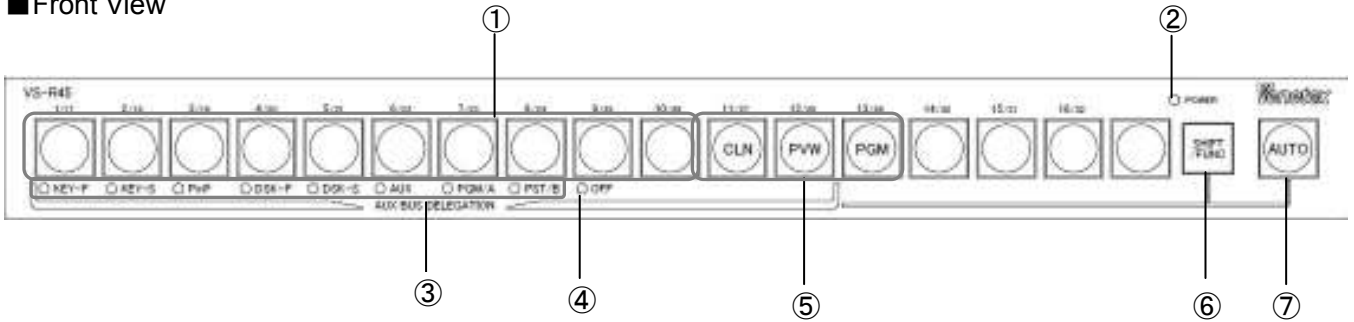

#### ① Material/Bus Selection Buttons

To select materials

To select a bus, press a button while pressing SHIF/FUNC + AUTO simultaneously. Button light will be on for the currently selected material.

#### ② Power Indicator

Green light is on when the device power is on.

#### ③ Bus Status Indicator

Indicates the current active bus.

Green light is on for the active bus.

#### ④ Key Lock Indicator

Green light is on when Key Lock is in effect.

#### ⑤ PGM/PVW Button

To select PGM or PVW Material.

Press once to choose PGM. Press once along with SHIFT/FUNC button for PVW.

#### ⑥ SHIFT/FUNC Button

To select Material #17 and up.

#### ⑦ Auto Button

To turn on AUTO Transition.

### ■ Rear View



#### ⑧ RS-422 Connector

Connector for RS-422 Cable

#### ⑨ Ground Terminal

To connect ground wire

#### ⑩ LAN Connector

To connect LAN cable

#### ⑪ Dip Switch for Mode Selection

Dip Switch allows you to select operation mode.

#### ⑫ Rotary Switch for Bus Selection

To assign the bus on initial power-up.

#### ⑬ DC Cable Clip

To fasten the device to avoid power cable disconnection

#### ⑭ DC Jack

Female DC plug

### 4-3. AV-HS410N Connection

#### ■ Front View

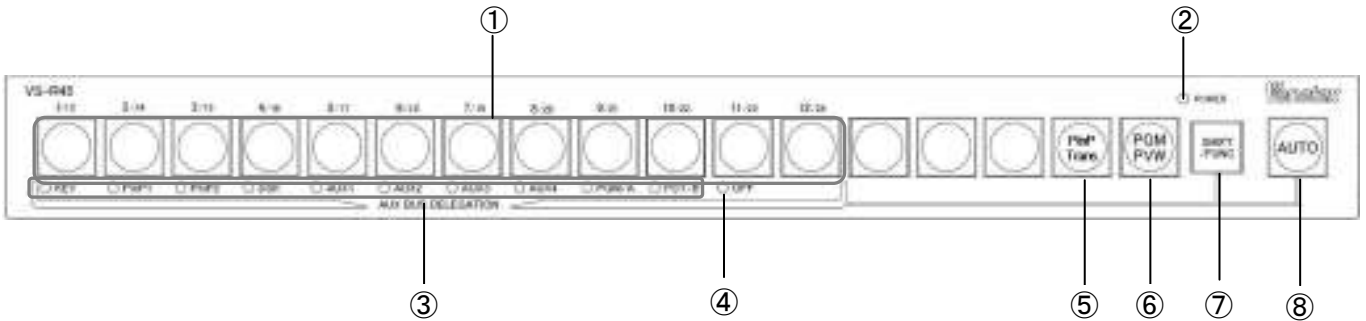

#### ① Material/Bus Selection Buttons

To select materials

To select a bus, press a button while pressing SHIF/FUNC + AUTO simultaneously. Button light will be on for the currently selected material.

#### ② Power Indicator

Green light is on when the device power is on.

#### ③ Bus Status Indicator

Indicates the current active bus.  
Green light is on for the active bus.

#### ④ Key Lock Indicator

Green light is on when Key Lock is in effect.

#### ⑤ PinP Trans bus

When PinP1/PinP2 is selected the transaction works.

#### ⑥ PGM/PVW Button

To select PGM or PVW Material.  
Press once to choose PGM. Press once along with SHIFT/FUNC button for PVW.

#### ⑦ SHIFT/FUNC Button

To select Material #13 and up.

#### ⑧ Auto Button

To turn on AUTO Transition.

#### ■ Rear View



#### ⑨ RS-422 Connector

Connector for RS-422 Cable

#### ⑩ Ground Terminal

To Connect ground wire

#### ⑪ LAN Connector

To connect LAN cable  
※Available in 2010

#### ⑫ Dip Switch for Mode Selection

Dip Switch allows you to select operation mode.

#### ⑬ Rotary Switch for Bus Selection

To assign the bus on initial power-up.

#### ⑭ DC Cable Clip

To fasten the device to avoid power cable disconnection

#### ⑮ DC Jack

Female DC plug

## 5. Operation Mode Settings

Use the dip switches on the rear panel to set the operation modes.  
Table 5.1 shows the operation mode settings

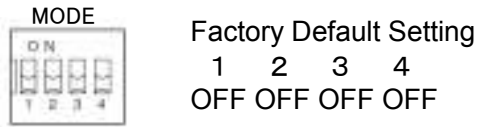

Table 5.1 Setting the Operation Mode

No	Type of Operation	Setting
1	Setting change for IP address setting and Firmware update	OFF: Normal position ON: Use for IP address setting and firmware update
2	Switch select	<b>2:OFF 3:OFF for AV-HS450</b>
3		<b>2:OFF 3:ON for AV-HS410N</b> <b>2:ON 3:OFF for AV-HS400A</b> <b>2:ON 3:ON for Prohibit the selection</b>
4	Disabling PGM/A, PST/B	OFF: PGM/A, PST/B Bus selection is available ON: PGM/A, PST/B Bus selection is prohibited

**AV-HS410N needs to download plug-in software from Panasonic homepage and needs to install it in switcher.**

## 6. Connecting

### 6-1. AV-HS450 Connection

You can connect VS-R45 and AV-HS450 as follows:

#### ■ Using RS-422 Cable

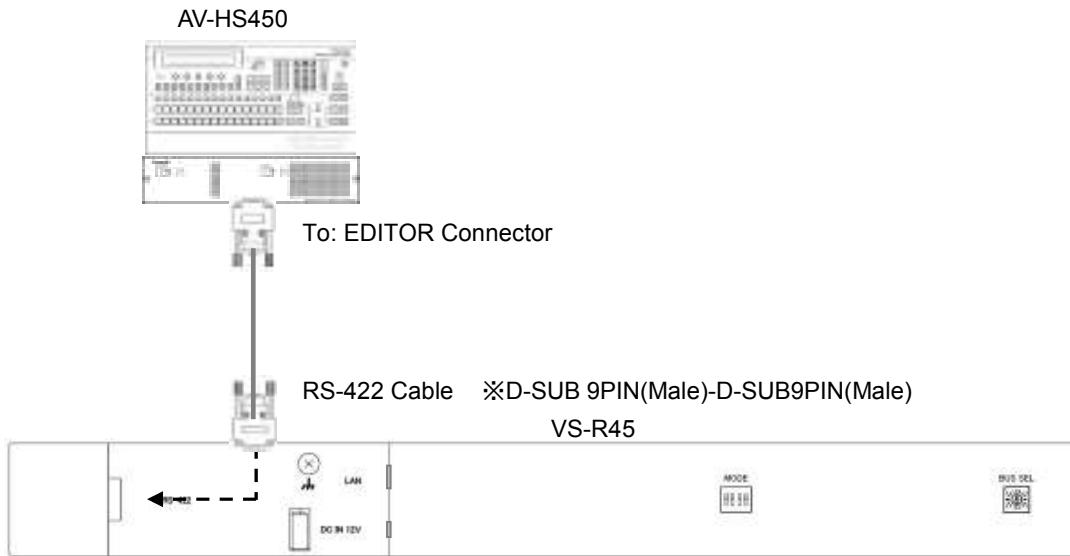

#### ■ LAN cable connection :

##### (1) pier to pier connection

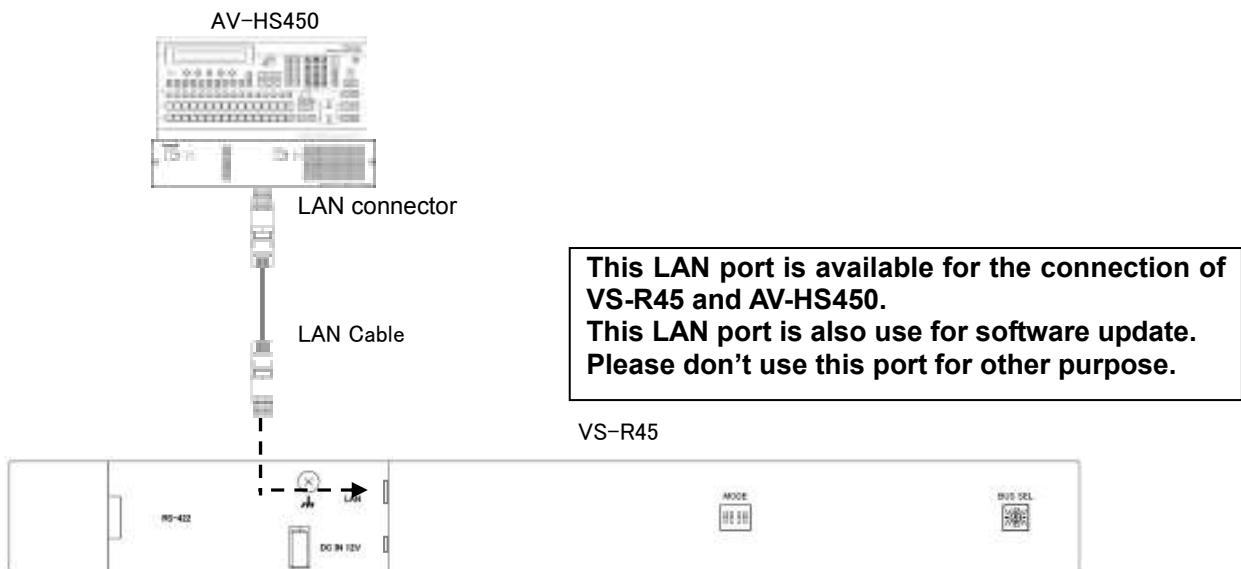

(2) Multiple connection

One AV-HS450 can connect maximum 4 units of VS-R45

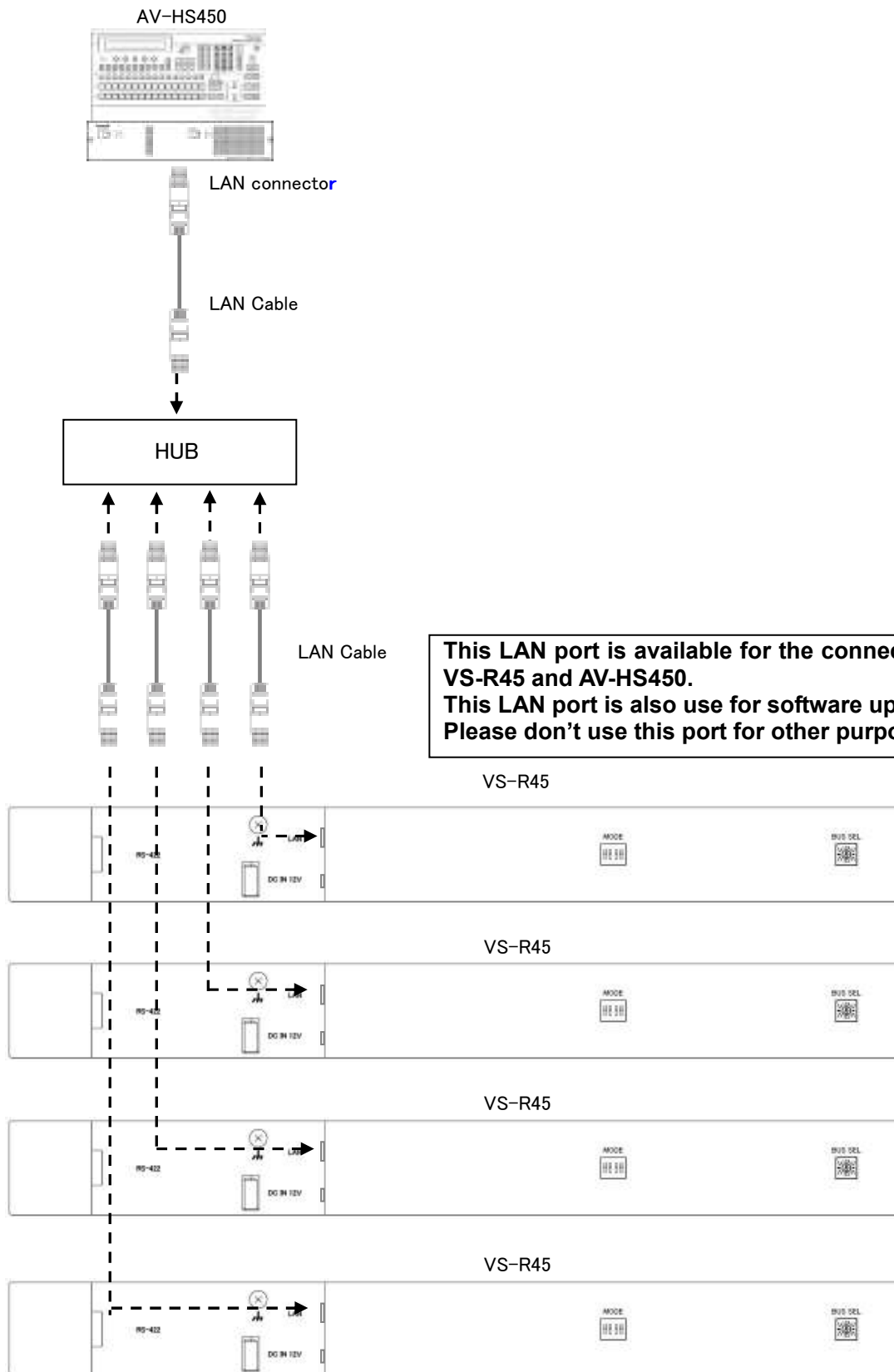

## 6-2. AV-HS400A Connection

You can connect VS-R45 and AV-HS400A as follows:

Remark: AV-HS400 with VS-R45 connection does not support LAN cable connection.

### ■ Using RS-422 Cable

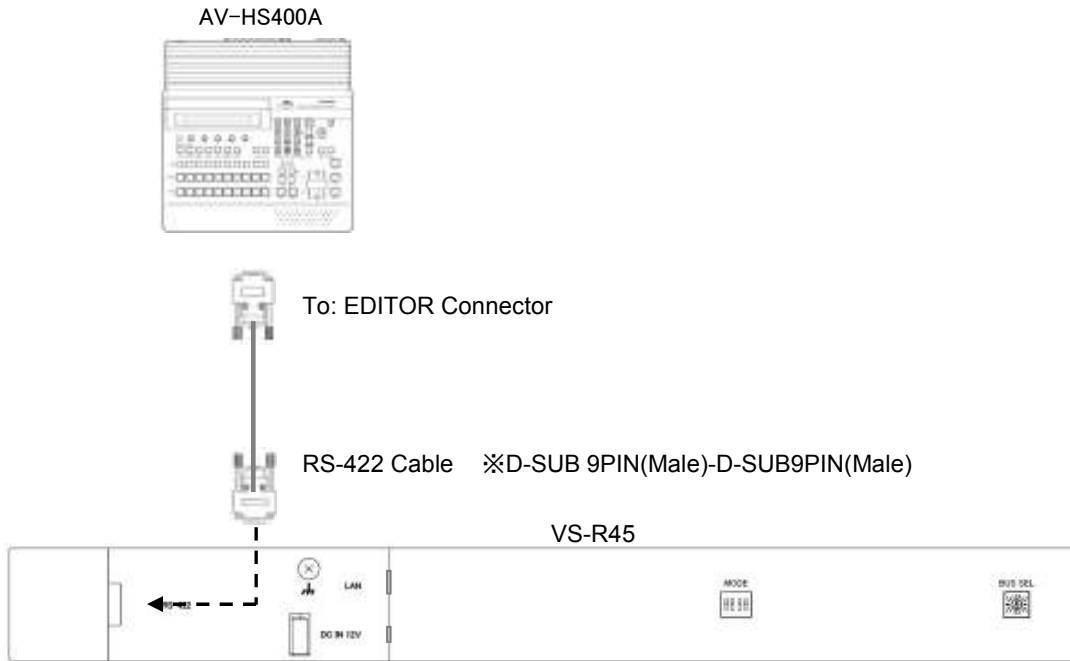

### 6-3. AV-HS410N Connection

You can connect VS-R45 and AV-HS410N as follows:

**Remark: AV-HS410N needs to download plug-in software from Panasonic homepage and needs to install it in switcher.**

#### ■ Using RS-422 Cable

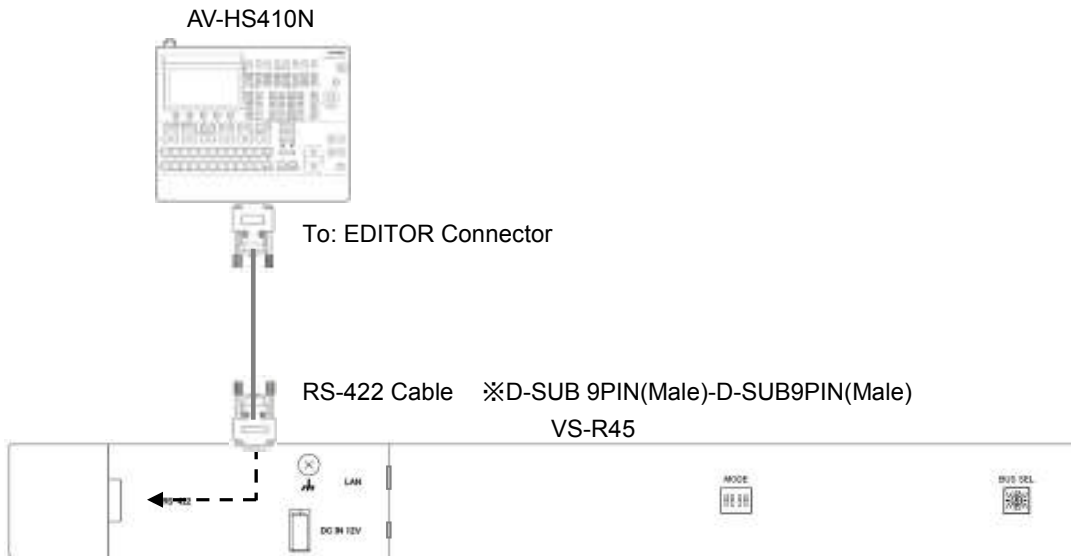

#### ■ LAN cable connection

##### (1) pier to pier connection

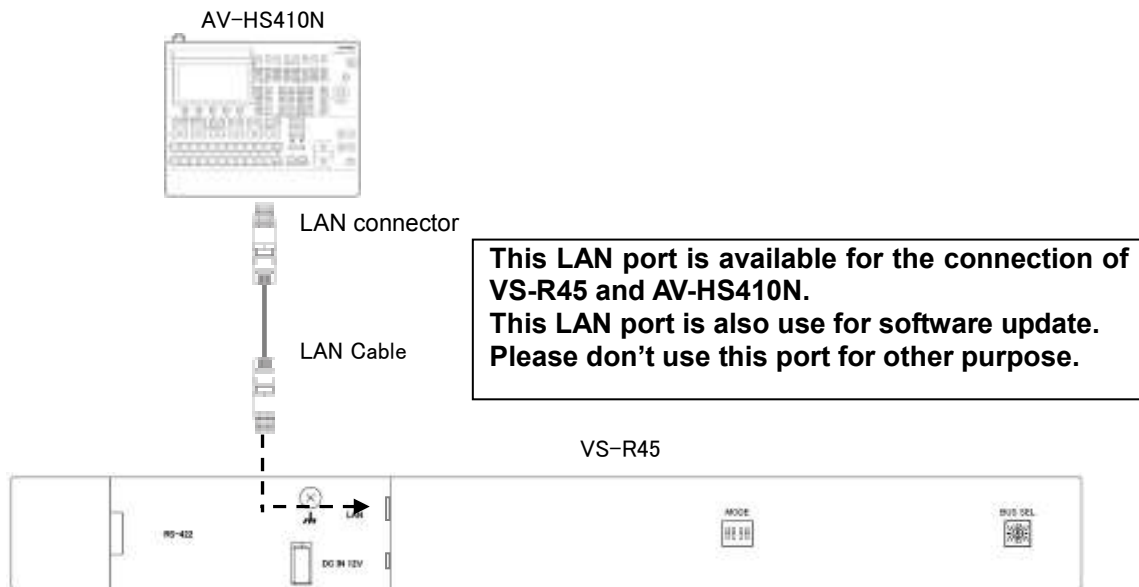



(2) Multiple connection

One AV-HS410N can connect maximum 4 units of VS-R45

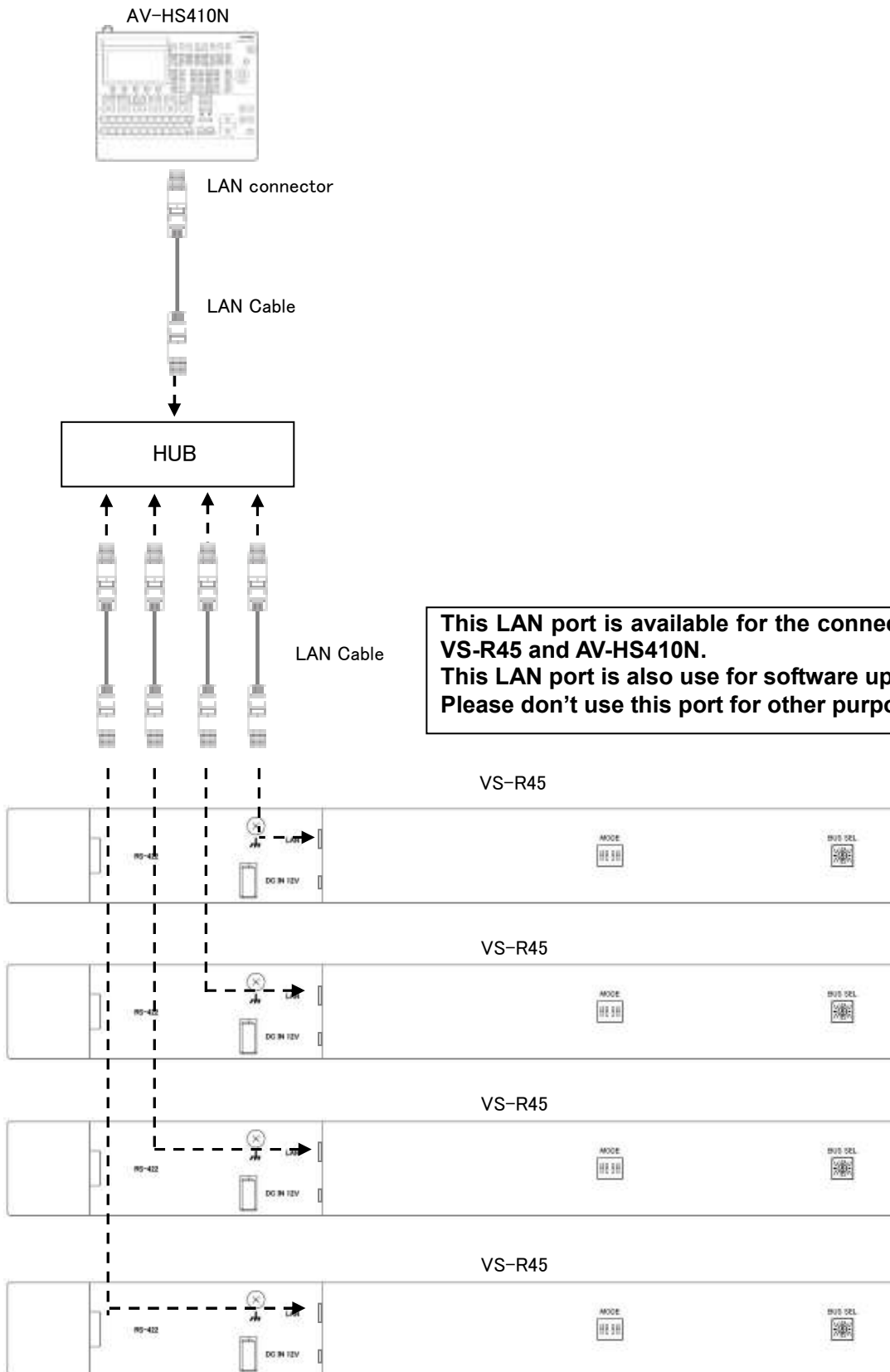

## 7. Turning on the Power

### ①Connecting DC Cable to the Unit

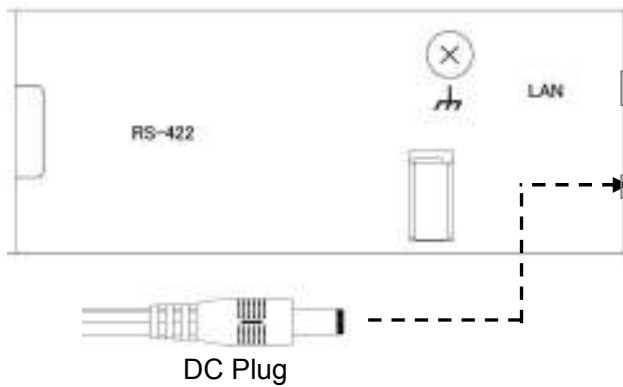

### ②Securing the DC Cable to the Unit

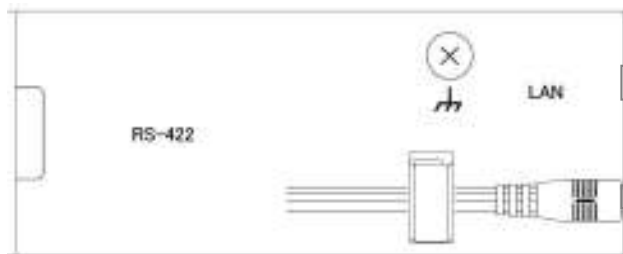

### ③Confirm the power is on

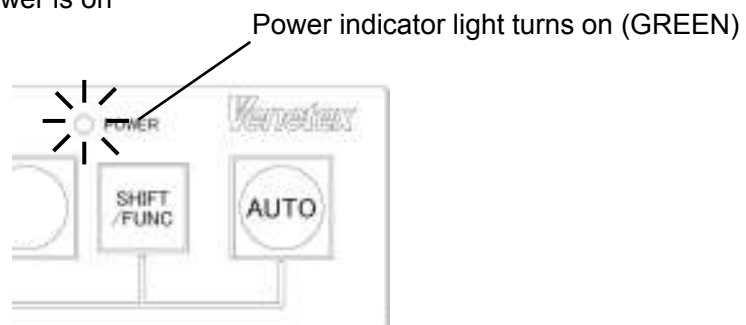

※Operation begins when the VS-R45 is powered up by DC input.

## 8. Operating the Unit

### 8-1. AV-HS450 Connection

Followings are sample operations after the VS-R45 unit is turned on.

#### 8-1-1. Turning on the Power

When the VS-R45 is powered up by DC input, all buttons on the front panel starts to flash in amber.

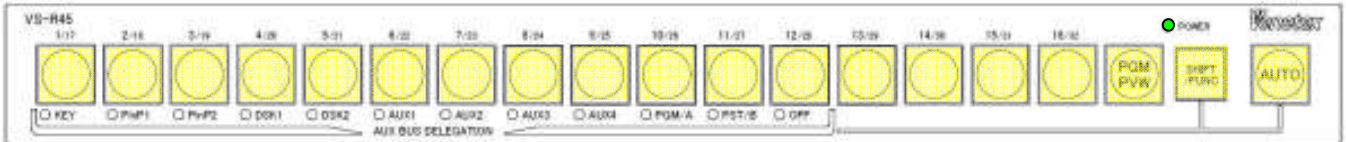

After Communication is established

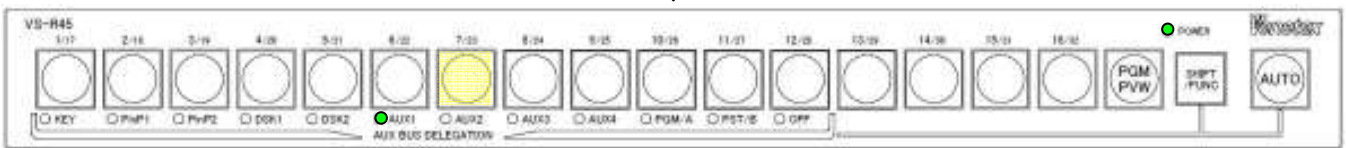

#### 8-1-2. Current Bus Status and Selecting Bus

When SHIFT/FUNC and AUTO buttons are simultaneously pressed, the light for the currently selected Bus turns AMBER. You can then select a different bus.

The following diagram shows that AUX1 Bus is currently selected. If PinP1 button is pressed, then AUX1 button comes OFF and instead PinP1 button light comes on in AMBER. Bus Status Indicator is also change to PinP1.

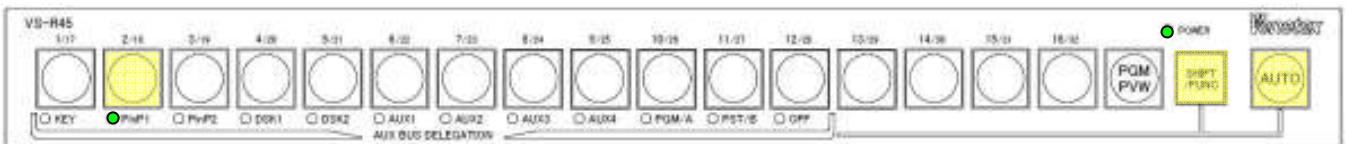
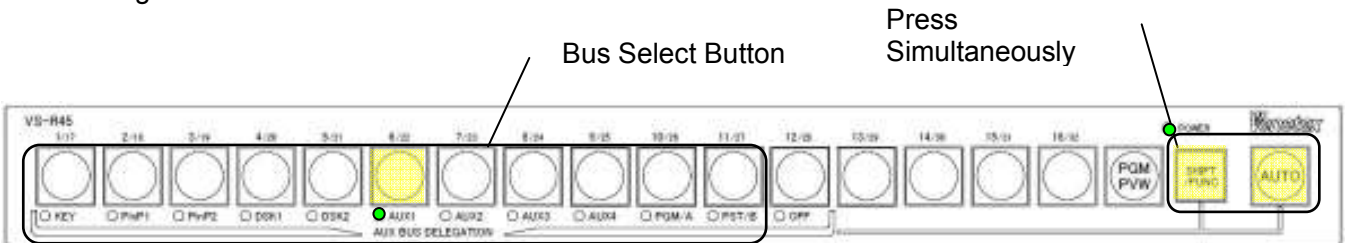

※When A/B bus mode is set on AV-HS450, the unit will always operate with PGM bus if PGM/A is selected and also with PST bus if PST/B is selected.

### 8-1-3. Key Lock

It employs the Key Lock feature to avoid button operation errors. Key Lock indicator light is on when the lock is on. Bus, material or AUTO Transition cannot be changed in this mode. Key Lock can be set ON or OFF by pressing the OFF button while pressing both SHIFT/FUNC and AUTO buttons simultaneously. Key Lock setting rotates between ON and OFF each time the OFF button is pressed.

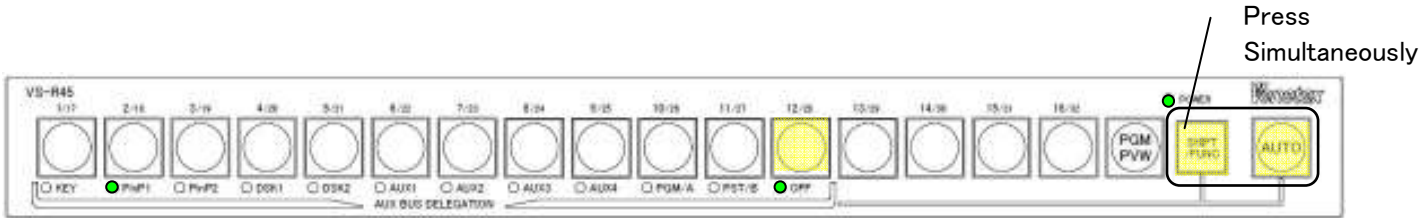

### 8-1-4. Selecting the Material

Button light comes on for the selected material. You can select from up to 32 types of materials. To select material #1 through #16, press a corresponding button once. To select material #17 through #32, pressing a corresponding button 1 through 16 with SHIFT/FUNC simultaneously. PGM/PVW material can be selected for AUX1 through AUX4 buses.

※It indicates the status of Material 1 to 16 when SHIFT/FUNC is OFF and 17 to 32 when SHIFT/FUNC is ON.

※When SHIFT feature is set on Cross Point Button with AV-HS450, corresponding button switches to the material assigned to each SHIFT.

Table 8.1.1 summarizes the relationship between the button operations and material selections.

It shows Material #13 when SHIFT/FUNC is OFF.

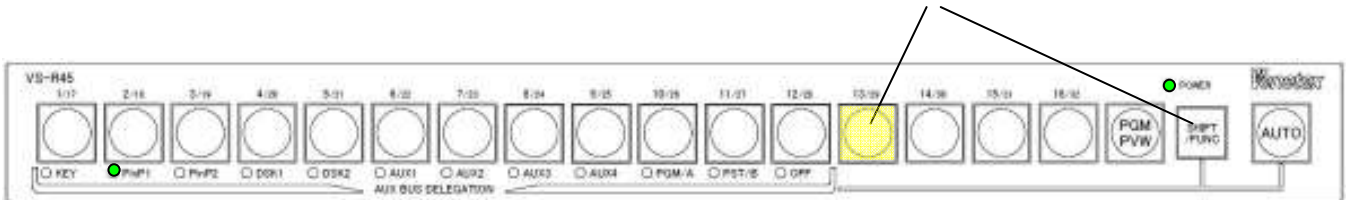

It shows Material #22 when SHIFT/FUNC is ON.



Table 8.1.1: Relationship between button operations and material selections

Button Operation	Material No.	Button Operation	Material No.
Press No. 1 button	Material 1	SHIFT/FUNC + No. 1 button	Material 17
Press No. 2 button	Material 2	SHIFT/FUNC + No. 2 button	Material 18
Press No. 3 button	Material 3	SHIFT/FUNC + No. 3 button	Material 19
Press No. 4 button	Material 4	SHIFT/FUNC + No. 4 button	Material 20
Press No. 5 button	Material 5	SHIFT/FUNC + No. 5 button	Material 21
Press No. 6 button	Material 6	SHIFT/FUNC + No. 6 button	Material 22
Press No. 7 button	Material 7	SHIFT/FUNC + No. 7 button	Material 23
Press No. 8 button	Material 8	SHIFT/FUNC + No. 8 button	Material 24
Press No. 9 button	Material 9	SHIFT/FUNC + No. 9 button	Material 25
Press No. 10 button	Material 10	SHIFT/FUNC + No. 10 button	Material 26
Press No. 11 button	Material 11	SHIFT/FUNC + No. 11 button	Material 27
Press No. 12 button	Material 12	SHIFT/FUNC + No. 12 button	Material 28
Press No. 13 button	Material 13	SHIFT/FUNC + No. 13 button	Material 29
Press No. 14 button	Material 14	SHIFT/FUNC + No. 14 button	Material 30
Press No. 15 button	Material 15	SHIFT/FUNC + No. 15 button	Material 31
Press No. 16 button	Material 16	SHIFT/FUNC + No. 16 button	Material 32

(1) Button Color for Material Selected

Button color of selected material differs depending on the selected bus.  
Table 8.1.2 summarizes the button color for each material selected.

Table 8.1.2: Button Colors for Selected Material

Order	Bus	Color of Button
1	KeyF Bus	Amber
2	KeyS Bus	Green
3	PinP1 Bus	Amber
4	PinP2 Bus	Amber
5	Dsk1F Bus	Amber
6	Dsk1S Bus	Green
7	Dsk2F Bus	Amber
8	Dsk2S Bus	Green
9	Aux1 Bus	Amber
10	Aux2 Bus	Amber
11	Aux3 Bus	Amber
12	Aux4 Bus	Amber
13	PGM/A Bus	Amber
14	PST/B Bus	Green
15	PGM	Amber
16	PVW	Green

## (2) Fill Bus & Source Bus

### •Key Bus

You can set the bus line to Key Fill or Key Source when Key Bus is selected.

(Each time the button is pressed, it alternates between Key Fill and Key Source. Button illuminates in Amber for Key Fill and Green for Key Source.)

### •DSK1 Bus

You can set the bus line to DSK1 Fill or DSK1 Source when DSK1 Bus is selected.

(Each time the button is pressed, it alternates between DSK1 Fill and DSK1 Source. Button illuminates in Amber for DSK1 Fill and Green for DSK1 Source.)

### •DSK2 Bus

You can set the bus line to DSK2 Fill or DSK2 Source when DSK2 Bus is selected.

(Each time the button is pressed, it alternates between DSK2 Fill and DSK2 Source. Button illuminates in Amber for DSK2 Fill and Green for DSK2 Source.)

## (3) PGM/PVW

PGM and PVW are also available in addition to Materials 1 through 32 when AUX1, AUX2, AUX3, or AUX4 bus is selected.

PGM mode is selected when PGM/PVW button is pushed.

PVM mode is selected when PGM/PVW and SHIFT/FUNC buttons are simultaneously pushed.

※PGM/PVW button is not assigned; the light of Bus will be blinking.

## 8-1-5. AUTO Button

Transition runs by pressing AUTO button when KEY, PinP1, PinP2, DSK1 or DSK2 bus is selected. When AUX1 bus is selected, AUX1 transition is effective if the light is on and not effective if the light is off.

※Button Indication will not correspond between AV-HS450 and VS-R45 if ON/OFF setting is changed from the menu on AV-HS450 after operating from the remote panel.

※The transition time of AUTO Transition is configured from AV-HS450 unit.

## 8-1-6. Selecting the Bus on Initial Power-up

Use the rear panel rotary switch to select the bus on initial power-up. Select the appropriate number to choose the bus. The bus setting with the rotary switch becomes invalid once the bus setting is changed from the front panel buttons.

Table 8.1.3 shows the correspondence of the rotary switch and the bus selection.

BUS SEL



Factory Default Setting: No.8

Table 8.1.3 Rotary Switch and Corresponding Bus

No.	Bus
0	KeyF Bus
1	KeyS Bus
2	PinP1 Bus
3	PinP2 Bus
4	Dsk1F Bus
5	Dsk1S Bus
6	Dsk2F Bus
7	Dsk2S Bus
8	Aux1 Bus
9	Aux2 Bus
A	Aux3 Bus
B	Aux4 Bus
C	PGM/A Bus
D	PST/B Bus
E	Unused (Aux1 Bus if selected.)
F	Unused (Aux1 Bus if selected.)

## 8-2. AV-HS400A Connection

Followings are sample operations after the VS-R45 unit is turned on.

### 8-2-1. Turning on the Power

When the device is powered up initially, All buttons on the front will be flashing on and off in Umber. When the communication with AV-HS400A is established, the lights on all buttons come OFF, and then the button and indicator light for currently selected material and bus will come on.

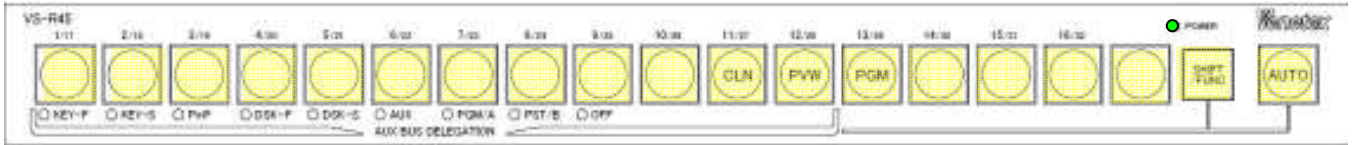

↓ After Communication is established

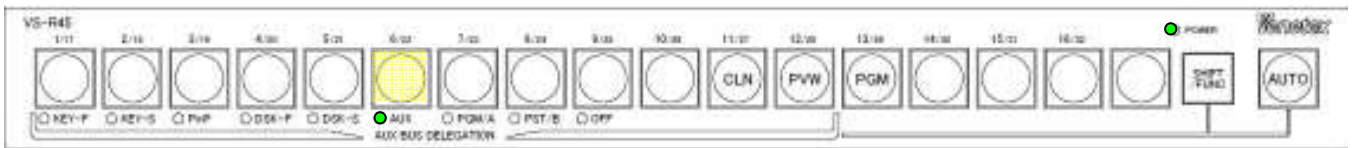

### 8-2-2. Current Bus Status and Selecting Bus

When SHIFT/FUNC and AUTO buttons are simultaneously pressed, the light for the currently selected Bus turns AMBER. You can then select a different bus.

The following diagram shows that AUX Bus is currently selected. If PinP button is pressed, then AUX button comes OFF and instead PinP button light comes on in AMBER. Bus Status Indicator is also change to PinP.

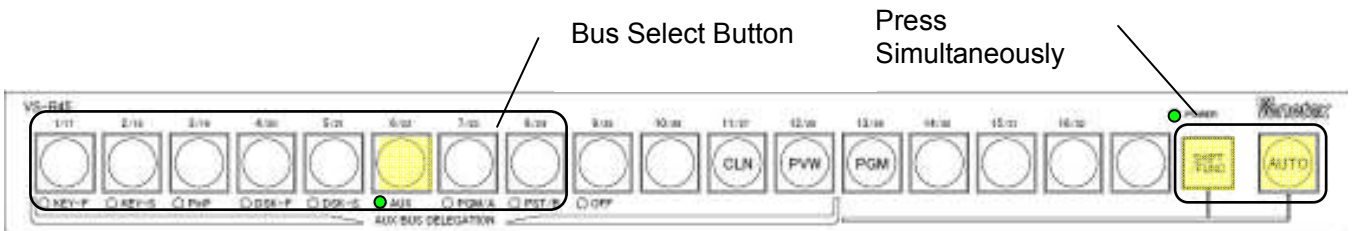

↓

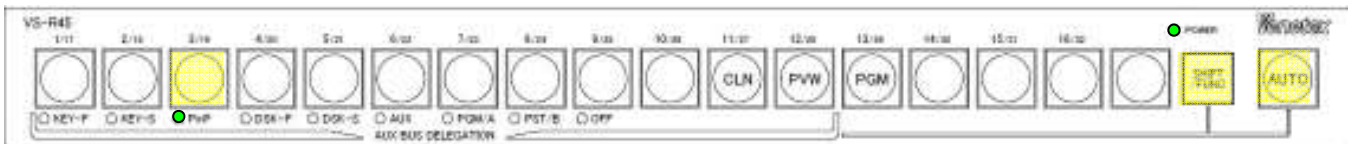



### 8-2-3. Key Lock

It employs the Key Lock feature to avoid button operation errors. Key Lock indicator light is on when the lock is on. Bus, material or AUTO Transition cannot be changed in this mode. Key Lock can be set ON or OFF by pressing the OFF button while pressing both SHIFT/FUNC and AUTO buttons simultaneously. Key Lock setting rotates between ON and OFF each time the OFF button is pressed.

Press  
Simultaneously

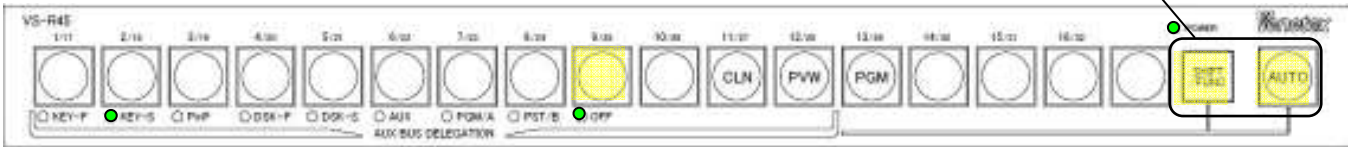

### 8-2-4. Selecting the Material

Button light comes on for the selected material. You can select from up to 10 types of materials. CLN, PVW, PGM can be selected through AUX Bus.

Table 8.2.1 shows relation between Bus operation and selected material.

Table 8.2.1: Relationship between button operations and material selections

Button Operation	Material No.
Press No. 1 button	Material 1
Press No. 2 button	Material 2
Press No. 3 button	Material 3
Press No. 4 button	Material 4
Press No. 5 button	Material 5
Press No. 6 button	Material 6
Press No. 7 button	Material 7
Press No. 8 button	Material 8
Press No. 9 button	Material 9
Press No. 10 button	Material 10

#### (1) Button Color for Material Selected

Button color of selected material differs depending on the selected bus. Table 8.2.2 summarizes the button color for each material selected.

Table 8.2.2: Button Colors for Selected Material

Order	Bus	Color of Button
1	Key-F Bus	Amber
2	Key-S Bus	Green
3	PinP Bus	Amber
4	DSK-F Bus	Amber
5	DSK-S Bus	Green
6	AUX Bus	Amber
7	PGM/A Bus	Amber
8	PST/B Bus	Green

## (2) Fill Bus & Source Bus

- Key-F Bus  
You can set the bus line to Key-F when Key-F Bus is selected.
- KEY-S Bus  
You can set the bus line to Key-S when Key-S Bus is selected.
- DSK-F Bus  
You can set the bus line to DSK-F when DSK-F Bus is selected.
- DSK-S Bus  
You can set the bus line to DSK-S when DSK-S Bus is selected.

## (3) CLN, PVW, PGM

CLN,PVW,PGM can be selected when AUX bus.

### 8-2-5. AUTO Button

Auto Transition runs by pressing AUTO button when is PGM/A, PST/B Bus is selected.

※AUTO Lamb lighting time does not link to Auto transition time of AV-HS400A

### 8-2-6. Selecting the Bus on Initial Power-up

Use the rear panel rotary switch to select the bus on initial power-up. Select the appropriate number to choose the bus. The bus setting with the rotary switch becomes invalid once the bus setting is changed from the front panel buttons.

Table 8.2.3 shows the correspondence of the rotary switch and the bus selection.



Table 8.2.3: Rotary Switch and Corresponding Bus

No.	Bus
0	Key-F Bus
1	Key-S Bus
2	PinP Bus
3	DSK-F Bus
4	DSK-S Bus
5	AUX Bus
6	PGM/A Bus
7	PST/B Bus
8	Unused (Aux1 Bus if selected.)
9	Unused (Aux1 Bus if selected.)
A	Unused (Aux1 Bus if selected.)
B	Unused (Aux1 Bus if selected.)
C	Unused (Aux1 Bus if selected.)
D	Unused (Aux1 Bus if selected.)
E	Unused (Aux1 Bus if selected.)
F	Unused (Aux1 Bus if selected.)

### 8-3. AV-HS410N Connection

Followings are sample operations after the VS-R45 unit is turned on.

#### 8-3-1. Turning on the Power

When the VS-R45 is powered up by DC input, all buttons on the front panel starts to flash in amber.

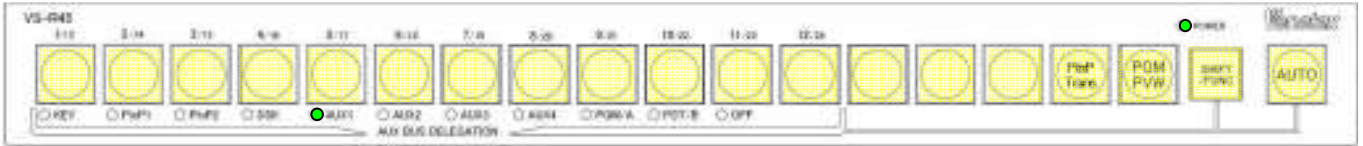

↓ After Communication is established

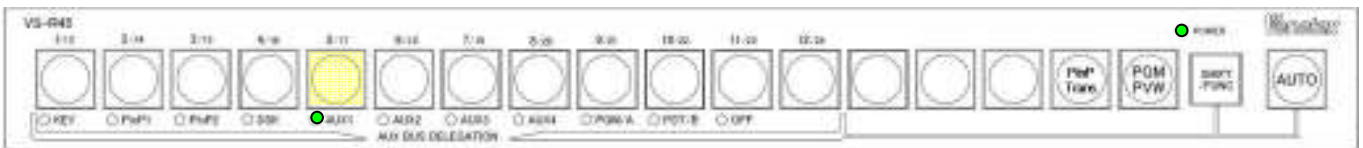

#### 8-3-2. Current Bus Status and Selecting Bus

When SHIFT/FUNC and AUTO buttons are simultaneously pressed, the light for the currently selected Bus turns AMBER. You can then select a different bus.

The following diagram shows that AUX1 Bus is currently selected. If PinP1 button is pressed, then AUX1 button comes OFF and instead PinP1 button light comes on in AMBER. Bus Status Indicator is also change to PinP1.

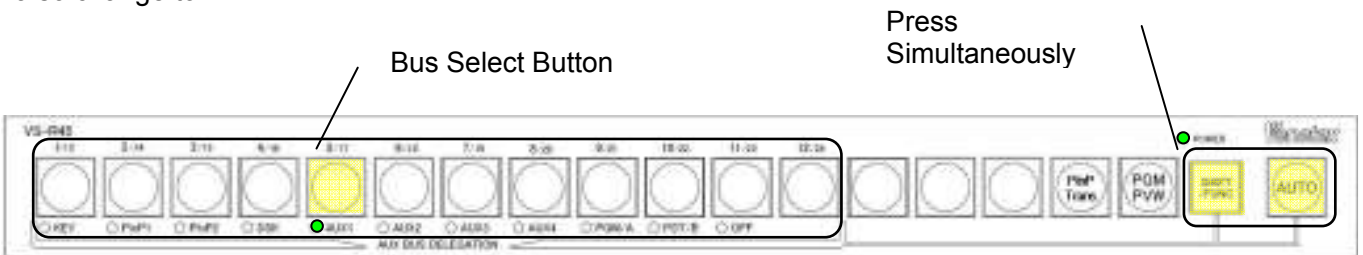

↓

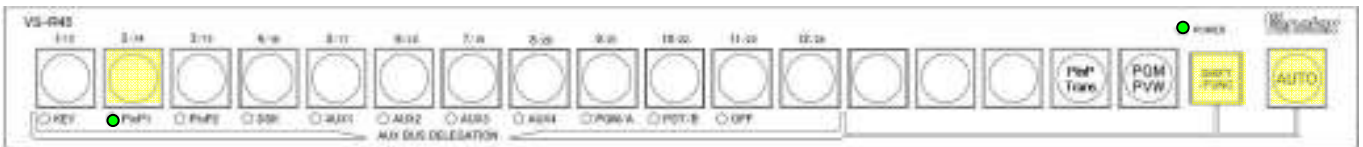

※When A/B bus mode is set on AV-HS410N, the unit will always operate with PGM bus if PGM/A is selected and also with PST bus if PST/B is selected.

### 8-3-3. Key Lock

It employs the Key Lock feature to avoid button operation errors. Key Lock indicator light is on when the lock is on. Bus, material or AUTO Transition cannot be changed in this mode. Key Lock can be set ON or OFF by pressing the OFF button while pressing both SHIFT/FUNC and AUTO buttons simultaneously. Key Lock setting rotates between ON and OFF each time the OFF button is pressed.

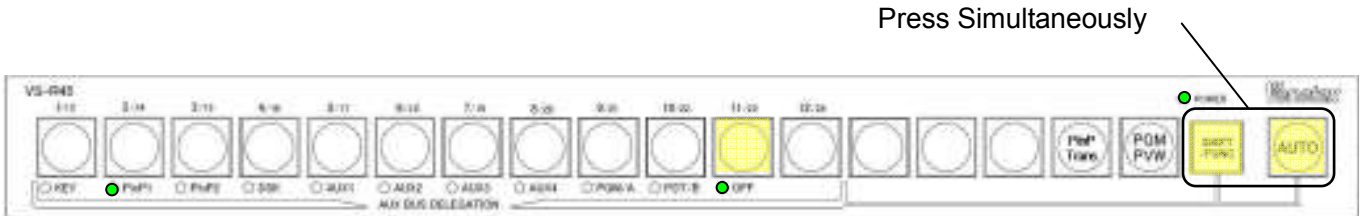

### 8-3-4. Selecting the Material

Button light comes on for the selected material. You can select from up to 24 types of materials. To select material #1 through #12, press a corresponding button once. To select material #13 through #24, pressing a corresponding button 1 through 12 with SHIFT/FUNC simultaneously. PGM/PVW material can be selected for AUX1 through AUX4 buses.

※It indicates the status of Material 1 to 12 when SHIFT/FUNC is OFF and 13 to 24 when SHIFT/FUNC is ON.

※When SHIFT feature is set on Cross Point Button with AV-HS410N, corresponding button switches to the material assigned to each SHIFT.

Table 8.3.1 summarizes the relationship between the button operations and material selections.

It shows Material #12 when SHIFT/FUNC is OFF.

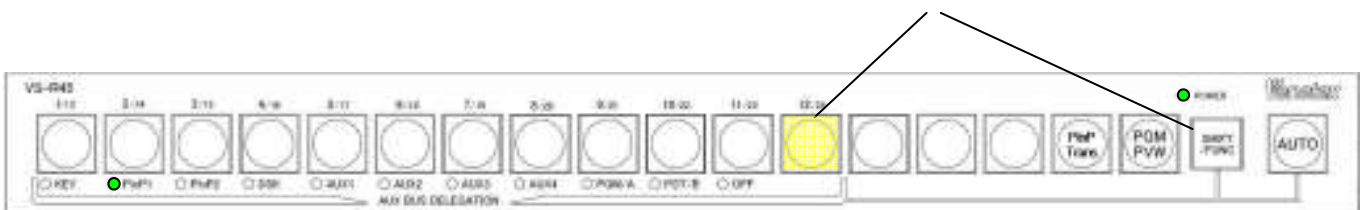

It shows Material #18 when SHIFT/FUNC is ON.



Table 8.3.1: Relationship between button operations and material selections

Button Operation	Material No.	Button Operation	Material No.
Press No. 1 button	Material 1	SHIFT/FUNC + No. 1 button	Material 13
Press No. 2 button	Material 2	SHIFT/FUNC + No. 2 button	Material 14
Press No. 3 button	Material 3	SHIFT/FUNC + No. 3 button	Material 15
Press No. 4 button	Material 4	SHIFT/FUNC + No. 4 button	Material 16
Press No. 5 button	Material 5	SHIFT/FUNC + No. 5 button	Material 17
Press No. 6 button	Material 6	SHIFT/FUNC + No. 6 button	Material 18
Press No. 7 button	Material 7	SHIFT/FUNC + No. 7 button	Material 19
Press No. 8 button	Material 8	SHIFT/FUNC + No. 8 button	Material 20
Press No. 9 button	Material 9	SHIFT/FUNC + No. 9 button	Material 21
Press No. 10 button	Material 10	SHIFT/FUNC + No. 10 button	Material 22
Press No. 11 button	Material 11	SHIFT/FUNC + No. 11 button	Material 23
Press No. 12 button	Material 12	SHIFT/FUNC + No. 12 button	Material 24

(1) Button Color for Material Selected

Button color of selected material differs depending on the selected bus.  
Table 8.3.2 summarizes the button color for each material selected.

Table 8.3.2: Button Colors for Selected Material

Order	Bus	Color of Button
1	KeyF Bus	Amber
2	KeyS Bus	Green
3	PinP1 Bus	Amber
4	PinP2 Bus	Amber
5	DskF Bus	Amber
6	DskS Bus	Green
7	Aux1 Bus	Amber
8	Aux2 Bus	Amber
9	Aux3 Bus	Amber
10	Aux4 Bus	Amber
11	PGM/A Bus	Amber
12	PST/B Bus	Green
13	PGM	Amber
14	PVW	Green

## (2) Fill Bus & Source Bus

### •Key Bus

You can set the bus line to Key Fill or Key Source when Key Bus is selected.

(Each time the button is pressed, it alternates between Key Fill and Key Source. Button illuminates in Amber for Key Fill and Green for Key Source.)

### •DSK Bus

You can set the bus line to DSK Fill or DSK Source when DSK Bus is selected.

(Each time the button is pressed, it alternates between DSK Fill and DSK Source. Button illuminates in Amber for DSK Fill and Green for DSK Source.)

## (3) PGM/PVW

PGM and PVW are also available in addition to Materials 1 through 24 when AUX1, AUX2, AUX3, or AUX4 bus is selected.

PGM mode is selected when PGM/PVW button is pushed.

PVM mode is selected when PGM/PVW and SHIFT/FUNC buttons are simultaneously pushed.

※PGM/PVW button is not assigned; the light of Bus will be blinking.

## 8-3-5. PinP Trans Button

PinP1 or PinP2 bus selection works as follows.

-PinP transition is valid (light turn on).

-PinP transition is not valid (light off)

※PinP transition time is defined by AV-HS410N.

## 8-3-6. AUTO Button

Transition runs by pressing AUTO button when KEY, PinP1, PinP2 or DSK bus is selected. When AUX1 bus is selected, AUX1 transition is effective if the light is on and not effective if the light is off.

※Button Indication will not correspond between AV-HS410N and VS-R45 if ON/OFF setting is changed from the menu on AV-HS450 after operating from the remote panel.

※The transition time of AUTO Transition is configured from AV-HS410N unit.

### 8-3-7. Selecting the Bus on Initial Power-up

Use the rear panel rotary switch to select the bus on initial power-up. Select the appropriate number to choose the bus. The bus setting with the rotary switch becomes invalid once the bus setting is changed from the front panel buttons.

Table 8.3.3 shows the correspondence of the rotary switch and the bus selection.



Factory Default Setting: No.8

Table 8.3.3 Rotary Switch and Corresponding Bus

No.	Bus
0	KeyF Bus
1	KeyS Bus
2	PinP1 Bus
3	PinP2 Bus
4	DskF Bus
5	DskS Bus
6	Aux1 Bus
7	Aux2 Bus
8	Aux3 Bus
9	Aux4 Bus
A	PGM/A Bus
B	PST/B Bus
C	Unused (Aux1 Bus if selected.)
D	Unused (Aux1 Bus if selected.)
E	Unused (Aux1 Bus if selected.)
F	Unused (Aux1 Bus if selected.)

## 9. System setup

Service application software and Installation software are available on Venetex homepage. Please download from homepage and store on your PC.

Venetex homepage : <http://www.venetex.jp/english>

The process of download and installation relies on your cautious procedures. Please pay attention to your work which Venetex could not assume responsibility.

### 9-1. IP Address setting

The following pages explain you IP address setup for LAN connection.

#### (1) Preparation for setup

Please prepare the following items.

- VS-R45
  - LAN cable (LAN cross cable is required for pier to pier connection)
  - Service Application Program
- With regard to service application and firmware software, please keep those in your PC.

#### (2) Connection method with PC and VS-R45

Please connect VS-R45 with PC through LAN cross cable.

Remark: If you connect VS-R45 with PC through LAN HUB unit, you can use either LAN cross cable or LAN straight cable.



#### (3) Pin 1 of SW1 and Power on of VS-R45:

Please tune Pin 1 to "on" position of the MODE switch 1 located on the rear panel of VS-R45.

Please refer to the attached picture.

Then connect DC input to VS-R45. It means Power ON.





(4) IP address setting through Internet Protocol(TCP/IP)  
Open Internet Protocol (TCP/IP) and open Property.  
Setting of IP address is as follows.

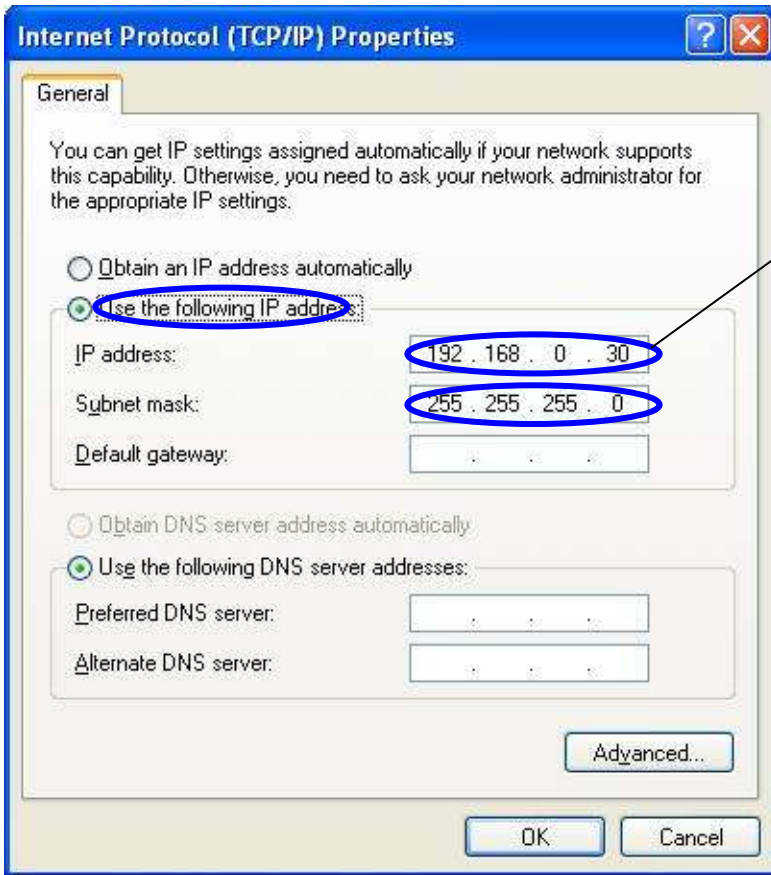

Please set as follows

(5) Preparation for Service Application Program :  
Please download Service Application software form Venetex Home Page.

<http://www.venetex.jp/english/>

This example shows that Icon of Service Application software“vs\_r45\_service\_api\_200.exe”is on the Desktop screen.

Double click the Icon “vs\_r45\_service\_api\_200.exe”.



Double click this ICON by the left mouse button

- (6) IP address confirmation.  
 Service application program is now starting..  
 Click "Read" button.  
 You can confirm IP address of VS-R45.

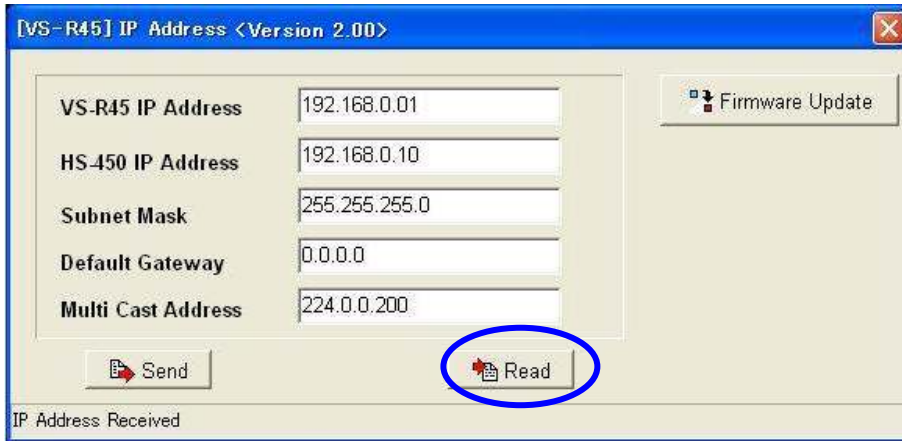

- (7) IP address setting.  
 Please enter each setting, confirm the each number and click the "Send" button.

※Remark:  
 It is no need to have IP address for AV-HS400A connection.

Please confirm the service application version 2.00 or higher.

VS-R45 IP address setting...  
 One AV-HS450 or AV-HS410 can be operated by maximum of four units of VS-R45.  
 Please note that each IP address of VS-R45 must be different.

Use the IP address of connected AV-HS450 or AV-HS410N.  
 Enter the same number of AV-HS450 or AV-HS410N IP address.

Please set to AV-HS450 or AV-HS410N Subnet Mask number.

Fix as 0.0.0.0

Fix as 224.0.0.200

- (8) "IP Address Set Complete" Screen appears on the status bar.  
This means that IP Address setting is completed.  
Click "x" button to close

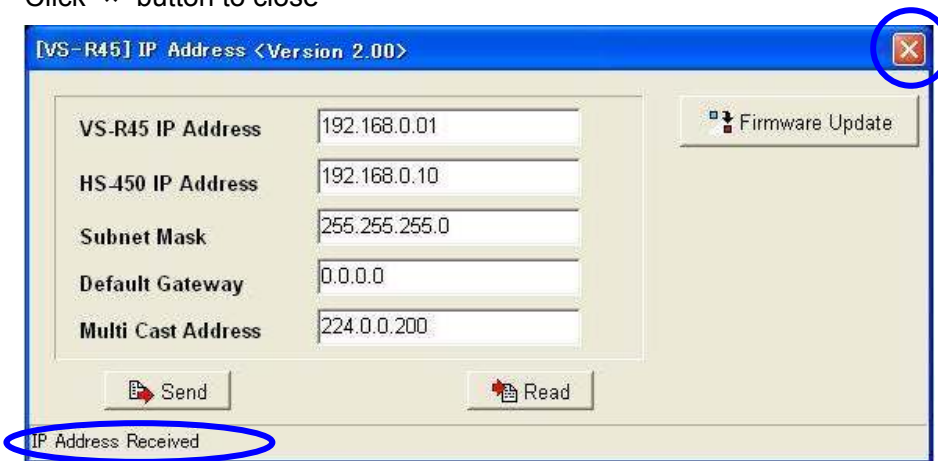

- (9) Start of the new software:  
Please turn Pin 1 to "OFF" on the MODE switch 1 located on the real panel of VS-R45.  
And disconnect DC input from VS-R45. It means Power OFF.  
Then connect DC input to VS-R45. It means Power ON.

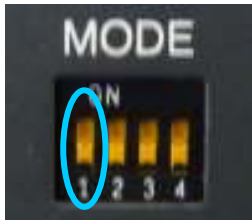

## 10. Specifications

### 10-1. Device Specifications

#### 10-1-1. AV-HS450 Connection

Table 10.1.1: Device Specifications (AV-HS450)

Item		Specification	Remarks
Name of Device		Remote Control Panel for Switcher	
Model No		VS-R45	
Intended Switcher (to use with)		AV-HS450 (Panasonic)	
Operation Switches	Material Selection Buttons	32 (Also used for Bus selection)	All buttons illuminate in Green, Red and Amber.
	PGM/PVW Button	1	
	SHIFT/FUNC Button	1 (Activate FUNCTION mode by pressing AUTO + SHIFT/FUNC)	
	AUTO Button	1 (Activate FUNCTION mode by pressing AUTO + SHIFT/FUNC)	
Control	RS-422	DSUB 9Pin	
	LAN	RJ-45 (10/100Base-T)	This LAN port is available for the connection of VS-R45 and AV-HS450. This LAN port is also use for software update. Please don't use this port for other purpose.
Power	Input	DC +12V±5%	
	Power Consumption	Less than 10W	
Operating Environment		0°C to 40°C (or 32F to 104F), 10% RH~90%RH (No condensation)	
Dimensions / Weight		1U size 420(W)×43.6(H)× 55(D)mm Less than 3Kg	
Safety and Environmental Compliance		RoHS, MET, CE, GOST, FCC, VCCI	

※Main bus: KEY, PinP1, PinP2, DSK1, DSK2, AUX1, AUX2, AUX3, AUX4, PGM/A, PST/B

※Features and specifications subject to change without notice.

10-1-2. AV-HS400A Connection

Table 10.1.2: Device Specifications (AV-HS400A)

Item		Specification	Remarks
Name of Device		Remote Control Panel for Switcher	
Model No		VS-R45	
Intended Switcher (to use with)		AV-HS400A (Panasonic)	V3.00.00~
Operation Switches	Material Selection Buttons	10 (Also used for Bus selection)	All buttons illuminate in Green, Red and Amber. Use for installation, update and maintenance purpose.
	CLN, PVW, PGM Select Button	1	
	SHIFT/FUNC Button	1 (Activate FUNCTION mode by pressing AUTO + SHIFT/FUNC)	
	AUTO Button	1 (Activate FUNCTION mode by pressing AUTO + SHIFT/FUNC)	
Control	RS-422	D-SUB 9Pin	Use for installation, update and maintenance purpose.
	LAN	RJ-45 (10/100Base-T)	
Power Supply	Model No	SPU16A-105	
	Input	AC 100~240V	
	Output	DC +12V	
	Power Consumption	Less than 10W	
Operating Environment		0°C to 40°C (or 32F to 104F), 10% RH ~90%RH (No condensation)	
Dimensions / Weight		1U size 420(W)×43.6(H)× 55(D)mm Less than 3Kg	
Safety and Environmental Compliance		RoHS, MET, CE, GOST, FCC, VCCI	

※Main bus: KEY, PinP, DSK, AUX, PGM/A, PST/B

※Features and specifications subject to change without notice.

10-1-3. AV-HS410N Connation

Table 10.1.3: Device Specifications (AV-HS410N)

Item		Specification	Remarks
Name of Device		Remote Control Panel for Switcher	
Model No		VS-R45	
Intended Switcher (to use with)		AV-HS410N (Panasonic)	
Operation Switches	Material Selection Buttons	24 (Also used for Bus selection)	All buttons illuminate in Green, Red and Amber.
	PGM/PVW Button	1	
	SHIFT/FUNC Button	1 (Activate FUNCTION mode by pressing AUTO + SHIFT/FUNC)	
	PinP Trans Button	1	
	AUTO Button	1 (Activate FUNCTION mode by pressing AUTO + SHIFT/FUNC)	
Control	RS-422	DSUB 9Pin	
	LAN	RJ-45 (10/100Base-T)	This LAN port is available for the connection of VS-R45 and AV-HS410N. This LAN port is also use for software update. Please don't use this port for other purpose.
Power	Input	DC +12V±5%	
	Power Consumption	Less than 10W	
Operating Environment		0°C to 40°C (or 32F to 104F), 10% RH~90%RH (No condensation)	
Dimensions / Weight		1U size 420(W)×43.6(H)× 55(D)mm Less than 3Kg	
Safety and Environmental Compliance		RoHS, MET, CE, GOST, FCC, VCCI	

※Main bus: KEY, PinP1,PinP2, DSK, AUX1, AUX2, AUX3, AUX4, PGM/A, PST/B

※AV-HS410N needs to download plug-in software from Panasonic homepage and needs to install it in switcher.

※Features and specifications subject to change without notice.

## 10-2. RS-422 Specifications

### (1) Type of Connector

D-SUB 9 PIN Female (DDK Brand: 17JE-13090-02)

### (2) Pin Assignment

Table 10.2: Pin Assignment

Pin No	Assignment
1	FG
2	RXD-
3	TXD+
4	GND
5	NC
6	GND
7	RXD+
8	TXD-
9	FG

(3) RS-422 Cable: should be used with D-SUB9PIN (Male) both end.

# 11. Outline Dimensions

## ■ Top View

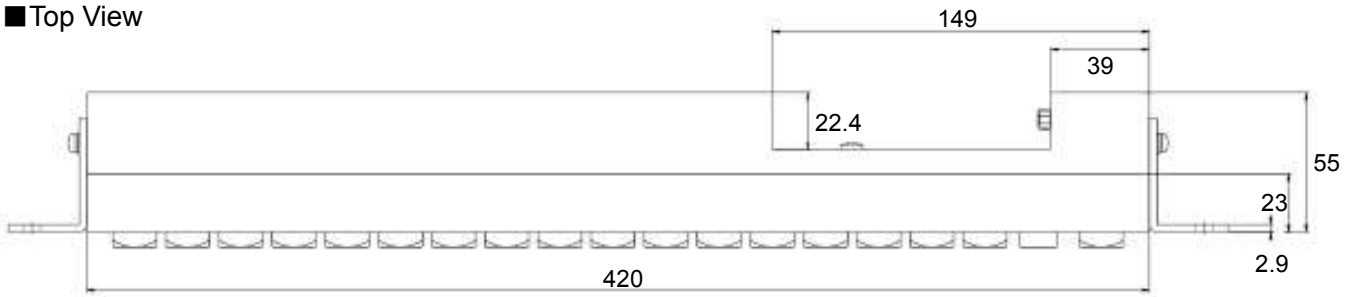

## ■ Front View

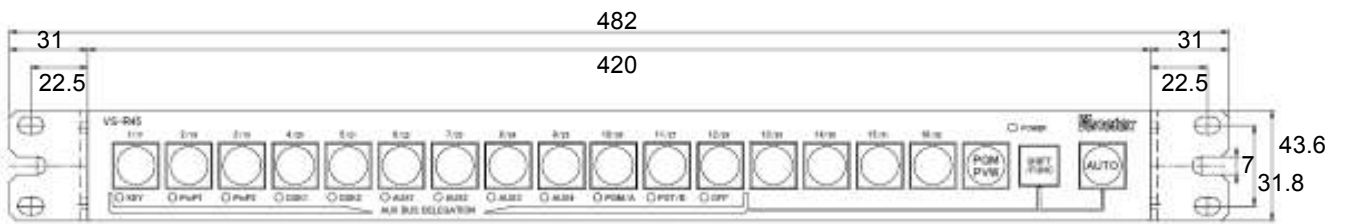

## ■ Side View

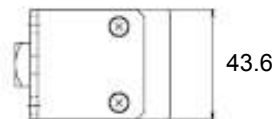



## 12. Customer Support

### (1) Warranty

Warranty period is limited to one year from the date of delivery.

Repairs are provided free of charge during the warranty period for conditions occurring under normal operations.

Such warranty includes software bug repairs occurring within one-year warranty period.

Repairs for the following conditions will be performed for a fee even within the warranty period:

- Breakdown and/or damage caused by an operational error or repair and/or alteration performed by an unauthorized party.
- Natural disaster, installation and environmental conditions such as vibrations, ambient temperature, moisture, dust and caustic gas.  
Breakdown and/or damage caused by the abnormal voltage or power supply not specified in the specifications (voltage/frequency).
- Breakdown and/or damage caused by the usage under the abnormal conditions not specified by the manufacturer.
- Breakdown and/or damage caused by other peripheral equipment or parts connected to the unit.
- Breakdown and/or damage of the consumable parts and items specified.

### (2) Requesting Repair Service

For all maintenance, please contact the dealer you purchased the unit from.

**【Please have the following information ready when contacting the Repair Department】**

- Company Name, Department, Name, Phone Number
- Product Name, Model Number, Dealer Name, Purchase Date
- Detailed Description of the Problem or Abnormal Condition
- Preference for Repair Date and Time

### (3) Firmware download and installation

The process of download and installation relies on your cautious procedures.

Please pay attention to your work which Venetex could not assume responsibility.

## Warranty Conditions

Products: Remote Control Panel for Multi Format Live Switcher (Panasonic)  
Model : VS-R45

Warranty Period: One Year

Serial No:

### Customer Information

Address:

Name of Company

Department

Name of person in charge

Phone No.

### Dealer Information

Address

Name of Company

Phone No.

Date of Purchase

Warranty provides free repair services for mechanical failures under the normal usage specified in the Operation manual.

For repair services, please contact the dealer that you purchased the unit from.

Please review "About Maintenance Services" in the operation manual for more information.

---

Venetex Corporation

8-3-9 Shin-machi, Ome-shi, Tokyo 198-0024, Japan

© VENETEX CORP 2012

---

# The connection and operation guide of VS-45 for AV-HS6000

## Important Information;

DIP switch setting mode of VS-R45 is the same as the AV-HS450.  
 This DIP switch is located on the real panel of VS-R45.

The different operation of AV-HS6000 are mentioned as bellow. Please make sure to read again VS-R45 manual which provides information about how to connect and handle.

## 1. Usage of Label sea;

(1) The below shows the supplied accessory label seal.



Please assign from AUX1 to AUX16 to each bus when you connect between VS-R45 and AV-HS6000, in accordance with the assignment of the bus of AV-HS6000, please paste the attached label seal for the bus assignments on top of the character show as example Fig-1.

(2) This is the example which KEY bus is assigned as AUX1;  
 The Fig-1 shows the example of pasting the label seal.  
 Please paste AUX1 label seal on KEX assigned silk print

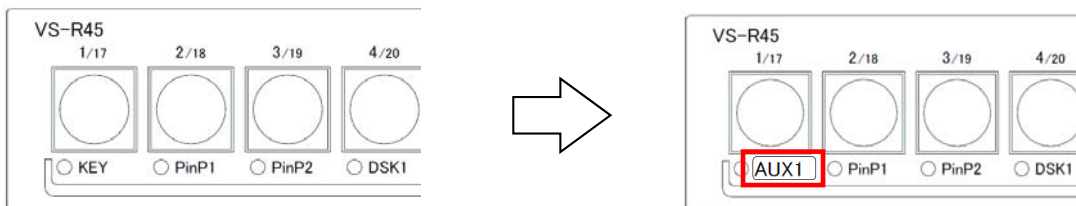

(A) The example of AV-HS450 panel

(B) The example of AV-HS6000 with label seal

Fig-1

## Remarks;

Bus names on the front panel of VS-R45 (KEY, PinP1, PinP2, DSK1 and etc.) correspond to the name of AV-HS450. Please refer to above (A) the example of AV-HS450.

For bus assign method of AV-HS6000, please refer to the operation manual of the AV-HS6000 Series Plug-in software.

For the unused or not assigned bus, please paste the blank seal on of the silk print.

## 2. Restriction of Usage;

- (1) In case of AV-HS6000, AUTO Transition function does not work by pressing short time of PGM / PVW button, and AUTO button.
- (2) Fill bus/Source bus cannot select.
- (3) Please create plug-in software of AV-HS6000 at your side, in case of using the RS-422 connection.
- (4) It is mandatory to start up the pre-installed Plug-in software of AV-HS6000.

## 3. Connection method;

With regard to LAN connection it is the same as AV-HS450.

In case of AV-HS6000 it is possible to connect with maximum 6 units of VS-R45.

Please connect LAN cable to the main frame (AV-HS60U1/ AV-HS60U12).

#### 4. For Material Button;

Relationship of Material buttons on the front panel, and material that is set in the AV-HS6000 is shown in Table 4.1.

Table 4.1: This table shows the relationship of material selection and button operation.

Button Operation	Material No.	Button Operation	Material No.
Press No. 1 button	Material that is assigned in the AV-HS6000 (XPTn)	SHIFT/FUNC + No. 17 Button	Material that is assigned in the AV-HS6000 (XPTn)
Press No. 2 button	Same as above	SHIFT/FUNC + No. 18 Button	Same as above
Press No. 3 button	Same as above	SHIFT/FUNC + No. 19 Button	Same as above
Press No. 4 button	Same as above	SHIFT/FUNC + No. 20 Button	Same as above
Press No. 5 button	Same as above	SHIFT/FUNC + No. 21 Button	Same as above
Press No. 6 button	Same as above	SHIFT/FUNC + No. 22 Button	Same as above
Press No. 7 button	Same as above	SHIFT/FUNC + No. 23 Button	Same as above
Press No. 8 button	Same as above	SHIFT/FUNC + No. 24 Button	Same as above
Press No. 9 button	Same as above	SHIFT/FUNC + No. 25 Button	Same as above
Press No. 10 button	Same as above	SHIFT/FUNC + No. 26 Button	Same as above
Press No. 11 button	Same as above	SHIFT/FUNC + No. 27 Button	Same as above
Press No. 12 button	Same as above	SHIFT/FUNC + No. 28 Button	Same as above
Press No. 13 button	Same as above	SHIFT/FUNC + No. 29 Button	Same as above
Press No. 14 button	Same as above	SHIFT/FUNC + No. 30 Button	Same as above
Press No. 15 button	Same as above	SHIFT/FUNC + No. 31 Button	Same as above
Press No. 16 button	Same as above	SHIFT/FUNC + No. 32 Button	Same as above

#### 5. Bus Select at Startup;

The setting of bus at startup is selected by the panel rotary switch located on the real panel.

Select the appropriate number to choose the bus. The bus setting with the rotary switch becomes invalid once the bus setting is changed from the front panel buttons.

Table 5.1 shows the correspondence of the rotary switch and the bus selection.

BUS SEL

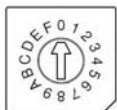

Factory Default Setting: No.8

Table 5.1: Rotary Switch and Corresponding Bus

No.	Bus	Silk print notation
0	AUX bus that is assigned to the KEY bus in AV-HS6000.	KEY
1	Setting prohibited	-
2	AUX bus that is assigned to PinP1 bus in AV-HS6000	PinP1
3	AUX bus that is assigned to PinP2 bus in AV-HS6000	PinP2
4	AUX bus that is assigned to DSK1 bus in AV-HS6000	DSK1
5	Setting prohibited	-
6	AUX bus that is assigned to DSK2 bus in AV-HS6000	DSK2
7	Setting prohibited	-
8	AUX bus that is assigned to AUX1 bus in AV-HS6000.	AUX1
9	AUX bus that is assigned to AUX2 bus in AV-HS6000.	AUX2
A	AUX bus that is assigned to AUX3 bus in AV-HS6000.	AUX3
B	AUX bus that is assigned to AUX4 bus in AV-HS6000.	AUX4
C	AUX bus that is assigned to PGM/A bus in AV-HS6000.	PGM/A
D	AUX bus that is assigned to PST/B bus in AV-HS6000.	PST/B
E	Unused. (When it is set, it is the same behavior as if you have selected the No. 8).	-
F	Unused. (When it is set, it is the same behavior as if you have selected the No. 8).	-